

Forus Australia provides products and services that benefit society and we grow in partnership with our customers and partners

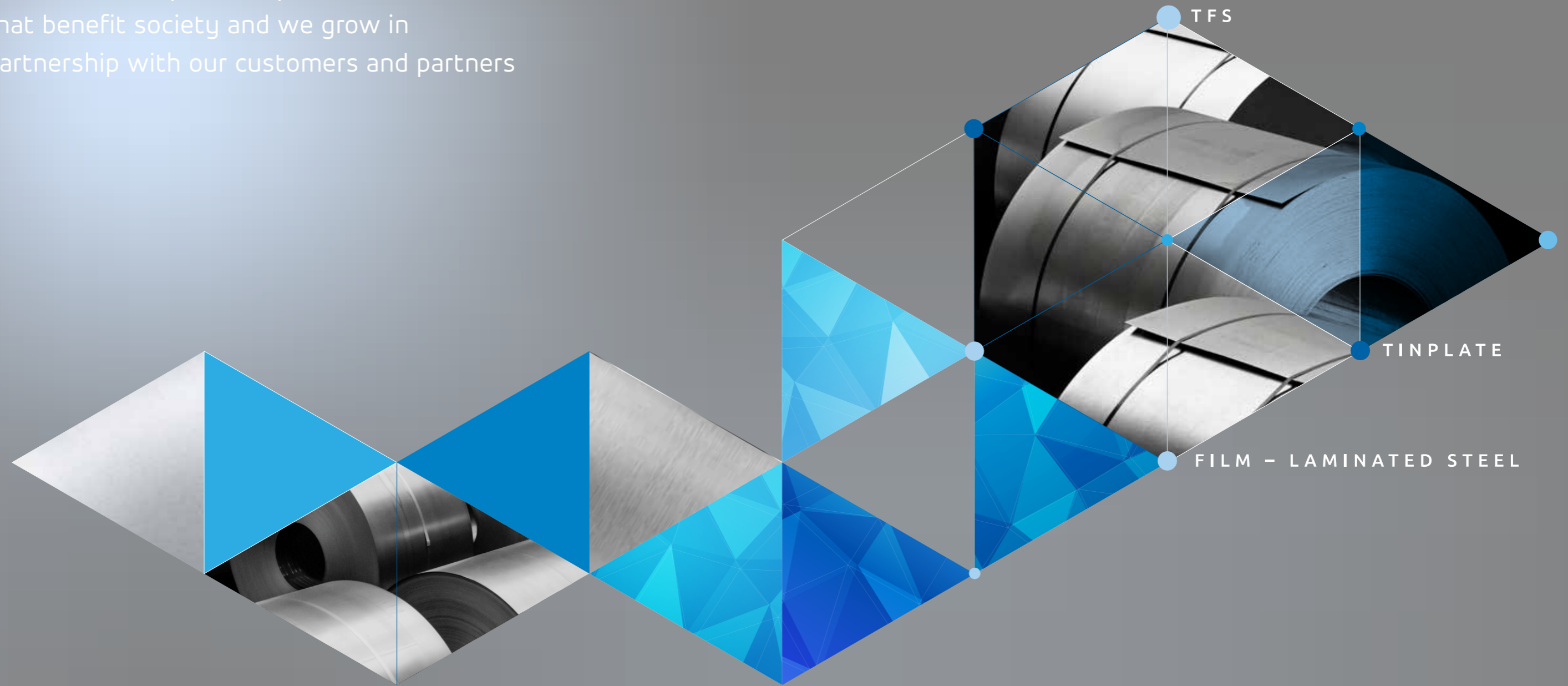

Please contact us to get more information

■ FORUS AUSTRALIA

📍 618/5 Alma road, Macquarie park, Sydney. 2113.
☎ +610452619660
✉ info@forusgroup.com

■ SALES REPRESENTATIVE

📍 Alexy Bugaev
☎ +61402215755
✉ a.bugaev@forusgroup.com



◀ Introduction

FORUS AUSTRALIA is a globally integrated enterprise with the headquarter in HONG KONG (HongKong Forus LTD, 2010) and branches in China (Shanghai Forus Metal Materials LTD.), Australia (Forus Australia PTY LTD) and Russia (LLC FORUS). We are committed to supplying premium steel product, metal coating/printing ink, metal packaging production systems and steel processing equipment worldwide. Strategic partnership with World leading manufacturers and service providers shapes our competitive advantage in supplying best quality product and service to our customers. Flexibility, innovation, collaboration and communication underpin Forus's principal imperative, which is **Providing One-stop, Customized and Comprehensive service for our product to our customers.**

FORUS AUSTRALIA is provides prepurchase service

- We provide detailed instruction data and standards of the manufacture's steel products.
 - We service our clients with instructions on correct selection of material.
-

FORUS AUSTRALIA is provides on-purchase service

- We provide order tracking information to ensure punctual goods delivery.
 - We perform sample inspection and make sure that the production is conducted in compliance with the contract.
-

FORUS AUSTRALIA is provides after sales service

- We provide clients with online query for certificated quality level.
- We provide clients with advisories for various problems met during the application.

CONTENTS

TINPLATE

- List Of Tin Mill Products 01
- Features 02
- Applications Of Tinplate And TFS 05
- Manufacturing Process 07
- Available Specifications And Sizes 09
- Usage Precautions 15
- Information Required With Orders And Inquiries 16

TIN FREE STEEL

- List Of Tin Mill Products 17
- Features 18
- Applications Of Tinplate And TFS 20
- Manufacturing Process 22
- Available Specifications And Sizes 24
- Usage Precautions 29
- Information Required With Orders And Inquiries 30

FILM – LAMINATED STEEL

- List Of Products 31
- Features 32
- Applications 33
- Manufacturing Process 34
- Available Specification And Size 34
- Instruction And Precaution 35
- Packaging And Marking 36
- Product Standard Or Protocol 37
- Requested Information Of Order Or Inquiry 37

TINPLATE

Tin mill products include electrolytic tinplate, electrolytic chromium coated steel (also referred to as tin free steel or TFS), and black plate, the uncoated steel. Tinplate is a thin steel sheet coated by tin, while TFS is an electrolytic chrome plated steel consisting of a thin layer of chromium and a layer of chromium oxide deposited on the steel base. Both of them have a beautiful, metallic luster as well as excellent properties in corrosion resistance and paintability.

List Of Tin Mill Products

Tin Mill Products

TINPLATE	SR
	DR

Note:
Tinplate includes K-tinplate, DI-tinplate, Low-Tin Plate, L-Cr Tinplate.

Coating Structure

ETP Products

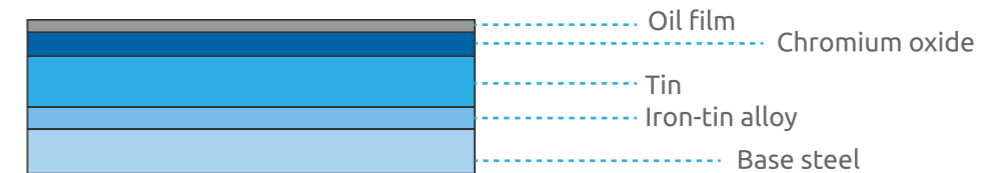

Features

Features of Tinplate Products

Excellent Corrosion Resistance	By selecting a proper coating weight, appropriate corrosion resistance is obtained against container contents.
Excellent Paintability & Printability	Printing is beautifully finished using various lacquers and inks.
Excellent Solderability & Weldability	TIN PLATE is widely used for making various types of cans by soldering or welding.
Excellent Formability & Strength	By selecting a proper temper grade, appropriate formability is obtained for various applications as well as the required strength after forming.
Beautiful Appearance	Electrolytic ETP is characterized by its beautiful metallic luster. Products with various kinds of surface roughness are produced by selecting the surface finish of the substrate steel sheet.

Different Features between TFS and ETP

Appearance	Even when the same surface finish as ETP is applied to the substrate steel sheet, it provides the unique surface luster characteristic of metallic chromium.
Corrosion resistance	As it has excellent corrosion resistance after painting, it is generally used with both surfaces painted. It can also be used with the internal surface unpainted, depending on the contents.
Solderability	TFS is not compatible with soldering.
Weldability	Although TFS can be welded when the metallic coating layers are removed, its weldability is inferior to ETP.
Coating weights	Unlike the multiplicity of coating weights with tin, only one standardized chromium-coated product is manufactured.

Comparison of Properties

		Tinplate		TFS
		2.8	Over 5.6	
Bare Corrosion ⁽¹⁾ Resistance (sealed)	Rust Resistance	○	⊙	○
	Acid Resistance	○	○	△
	Alkali Resistance	△	△	⊙
	Black Sulfide Stain Resistance	△	△	⊙
	Stress Cracking Resistance	⊙	⊙	○
Paintability		○	○	⊙
Corrosion Resistance after Painting ⁽²⁾		⊙	⊙	○
Filiform Corrosion Resistance		⊙	⊙	⊙
Paint Adhesion		○	○	⊙
Formability		⊙	⊙	○
Solderability		○	⊙	✘
Weldability		○	○	△ ⁽³⁾
Heat Resistance ⁽⁴⁾		○	○	⊙

⊙ excellent ○ good △ fair ✘ poor

Note:

(1) Bare corrosion resistance is evaluated under tightly sealed conditions.

(2) Corrosion resistance after painting is evaluated by crosshatching corrosion tests.

(3) The evaluation is for the case where welding is performed without grinding the surface to remove the metallic coating layer.

(4) High-temperature baking after painting and printing may cause changes in material properties.

Advantages of Tinplate Cans in Food Packaging

Hygienic	Provide excellent and non-toxic barrier properties to protect food products from impurities, bacteria, moisture, light, and odours.
Safe	Low weight and high strength make food cans easy to ship and store.
Eco-friendly	Offer 100% recyclability; and significant cost benefits compared with aluminum.

K-Tinplate's Resistance to Corrosion

Pickling Lag Value	Iron Solution Value	Tin Crystallite Size	Alloy-Tin Couple
≤ 10 Sec	≤ 20µg/3in ²	≤ 9#	≤ 0.12µA/3in ²

Note:
If different coating tinplate, the side of higher coating weight was tested

Mechanical Properties of DR Tin Mill Products

Temper Grade	(HR30Tm) Hardness		Yield Strength/ MPa
	Target Value	Range	
DR-7M	71	71±5	520
DR-8	76	73±5	550
DR-8M	77	73±5	580
DR-9	73	76±5	620
DR-9M	73	77±5	660
DR-10	80	80±5	690

Note:
Making cans with DR materials, please pay a special attention to the rolling direction.

Applications Of Tinplate And TFS

Consumer Packaging and Industrial Packaging

TINPALTE	ETP is primarily used for packaging foodstuffs and beverages, but it is also used in containers for oils, grease, paints, polishes, chemicals and many other products. Aerosol containers and caps and closures are also made from ETP.
TFS	TFS are most frequently used for can tops, screw and lug caps, snap and press-on closures and shallow-drawn food cans.

Miscellaneous

in Electronics	Electrodes, Cable tape, Magnetic screen covers, etc.
in Engineering	Automotive oil filters, Automotive air filters, Gaskets, etc.
in Construction	Gas meter internal components, Heat exchangers, cookware, shelving, etc.



Application Examples

DI can

Two-piece steel can represents the highest development level of tinplate production. Nowadays, Our DI material is used for two-piece can to pack beer and carbonated beverage such as CocaCola and Pepsi-cola.



Three-piece can for beverage

Representative Clients: Include Wanglaoji, Redbull, Robust, Etc.



Food can (3-piece can & 2-piece can)

Our tin mill products are used for the package of all kinds of canned food such as Huangguan, Meilin and Gulong.



Metal closure and ends

Our tinplate and TFS are used for Budweiser, Harbin and Yanjing beer, etc. Our the major supplier of Ziquan Group, Huapeng closures, Yiwu Easy Open End Industry Group, etc.



Spray can

Clients are Hangzhou Meite, Shenzhen Huate, zhongshan Kaida, etc.



High-grade industrial package

Tinplate and TFS are used for the package of Nippon, International Paint, Sigma.



High-grade gift package

Irregular cans are made from Our tinplate and TFS for high-grade gift package.



Manufacturing Process

Process Diagram

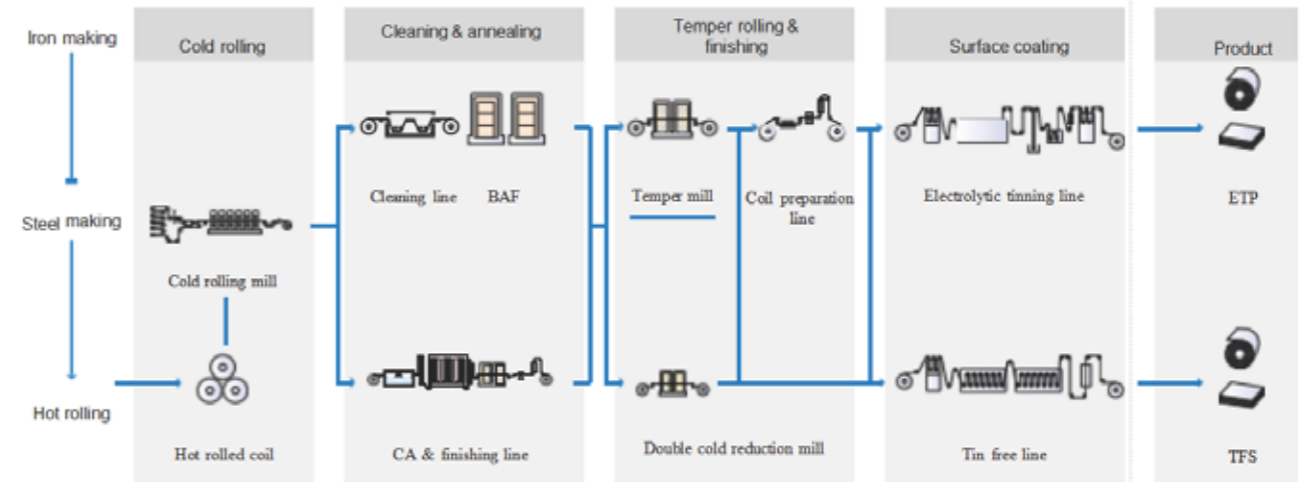

Note:

Tinplate and TFS products are manufactured under strict quality control all through the manufacturing process to provide the excellent corrosion resistance and uniform material properties required of can-making materials.



Major Control Items in the Manufacturing Process

Steelmaking	Steelmaking: Chemical composition, minimization of inclusions.
Hot Rolling	Finishing temperature, coiling temperature, gage profile.
Cold Rolling	Gage, flatness.
Annealing	Heating temperature, soaking temperature, cooling temperature, atmospheric gas composition.
Temper Rolling	Shape, surface roughness.
Electrolytic Plating	Coating weight, chemical treatment, oiling amount.

ETP and TFS's Parameters Inspected

A	Mechanical Properties	Hardness (temper grade)
B	Dimensional Accuracy	Thickness Width Cut-length
C	Shape Parameters	Bowness Camber Askewness Edge waviness
D	Lubrication	Oil film
E	Corrosion Resistant Property	Tin coating (for Tinplate) Metallic chromium and chromium in Cr-oxide (for TFS) Passivation film weight Alloy-tin Couple (for required) Iron solution value (for required) Tin grain size (for required) Corrosion resistance SO2 test (for required) Porosity Test (for required) Pickling lag value (for required)

Available Specifications And Sizes

Steel Types

Steel grade	Characteristics	Products
MR	Base steel low in residual elements that has excellent corrosion resistance, widely used in general applications.	ETP, TFS
L	Base steel extremely low in residual elements such as Cu, Ni, Co, and Mo that has excellent corrosion resistance to certain types of food products.	ETP, TFS
D	Aluminum-killed base steel used in applications involving deep drawing or other types of severe forming that tend to give rise to Lueder's lines.	ETP

Note:
With regard to steel types other than those listed above, please consult us.

Available Sizes

ETP

Black Plate	Normal Thickness	Normal Width	Normal Length (sheet)
Single Reduce	0.17 ~ 0.55mm	700 ~ 1200mm	500 ~ 1168mm
Double Reduce	0.12 ~ 0.36mm		

Temper Grade

Black Plate	Box Annealing	Continuous Annealing
Single Reduce	T-1, T-2, T-2.5, T-3	T-1.5, T-2.5, T-3, T-3.5, T-4, T-5
Double Reduce	DR-7M, DR-8, DR-8M, DR-9, DR-9M, DR-10	

Note:
(1) There are two types of annealing: batch annealing(BA) and continuous annealing(CA). When continuous annealing is designated, the symbol of "CA" is added after the temper grade symbol such as "T-4CA".
(2) The DR materials can also be manufactured by box annealing, Normal Width limited from 700~1050mm. Please consult us.

Coating Weight

ETP

	Former Coating Designation	Coating Weight Code	Nominal Coating Weight (g/m ²)	Minimum average Coating Weight (g/m ²)
Equally Coated	10#	1.1/1.1	1.1/1.1	0.9/0.9
	20#	2.2/2.2	2.2/2.2	1.8/1.8
	25#	2.8/2.8	2.8/2.8	2.5/2.5
	50#	5.6/5.6	5.6/5.6	5.2/5.2
	75#	8.4/8.4	8.4/8.4	7.8/7.8
	100#	11.2/11.2	11.2/11.2	10.1/10.1
Differentially Coated	25#/10#	2.8/1.1	2.8/1.1	2.5/0.9
	50#/10#	5.6/1.1	5.6/1.1	5.2/0.9
	50#/25#	5.6/2.8	5.6/2.8	5.2/2.5
	75#/25#	8.4/2.8	8.4/2.8	7.8/2.5
	75#/50#	8.4/5.6	8.4/5.6	7.8/5.2
	100#/25#	11.2/2.8	11.2/2.8	10.1/2.5
	100#/50#	11.2/5.6	11.2/5.6	10.1/5.2
	100#/75#	11.2/8.4	11.2/8.4	10.1/7.8
	125#/50#	15.1/5.6	15.1/5.6	13.9/5.2

Note:

(1) The tin coating weight is determined in accordance with specific end use applications. Tinplate with a heavy coating weight is used for making cans that require a high corrosion resistance or those used bare. Tinplate with a light coating weight is used for making cans that do not require so high a corrosion resistance or those used after painting or printing.

(2) Differential Markings A white line (differential marking) is painted along the edge of a differentially coated product in order to clearly indicate that it is differentially coated.

(3) With regard to other types of differential markings, please consult us.

Surface Finishes

ETP

Black Plate	Code	Surface Finish	Characteristics
Single Reduce	B	Bright surface	Glazed surface obtained after melting treatment of electro tinned smooth raw material strip with extremely fine stone figures by processing.
	R	Stone surface	Glazed surface obtained after melting treatment of electro-tinned raw material strip featuring certain oriented stone figures.
	R2	Stone rough surface	Glazed surface obtained after melting treatment of electro-tinned raw material strip featuring certain oriented stone figures, roughness higher than "R".
	S	Silver surface	Glazed surface obtained after melting treatment of electro-tinned raw material strip with rough matt surface.
	S2	Silver rough surface	Glazed surface obtained after melting treatment of electro-tinned raw material strip with rough matt surface, roughness higher than "S".
	M	Matte surface	Matt surface of general matt raw material strip without reflowing treatment.
	Double Reduce	R	Stone surface
M		Matte surface	Matt surface of general matt raw material strip without reflowing treatment.

Oiling

- If no engagement, tinplate and TFS are electro statically oiled with DOS.

	Temper	Nominal Thickness (mm)	Nominal Width (mm)	
SR-BA	T-2BA	0.22-0.50	700-960	
	T-2.5BA,T-3BA	0.19	700-860	
		0.20	700-900	
		0.21	700-920	
		0.22-0.23	700-940	
		0.24-0.50	700-960	
DR-CA	DR520 DR7M	0.15	700-880	
		0.16	700-920	
		0.17	700-940	
		0.18-0.28	700-970	
		0.29-0.40	800-970	
	DR550 DR8	0.14	700-880	
		0.15-0.16	700-920	
		0.17-0.26	700-970	
		0.27-0.38	800-970	
	DR580 DR8M	0.14	700-920	
		0.15	700-950	
		0.16-0.25	700-970	
		0.26-0.36	800-1000	
	DR620 DR9	0.14	700-940	
		0.15-0.23	700-970	
		0.24-0.34	800-1000	
	DR-BA	DR520 DR7M	0.15	700-880
			0.16-0.17	700-900
0.18-0.40			700-960	
DR550 DR8		0.14	700-820	
		0.15	700-900	
		0.16	700-920	
		0.17-0.37	700-960	

Usage Precautions

Usage Precautions for ETP

- 01 As ETP is covered by soft metallic tin coatings, due precautions should be taken not to cause scratches by rough handling or vibration during transportation.
- 02 Paintability, printability, solderability, and mechanical properties of ETP tend to deteriorate as time elapses after production. Use as soon as possible after delivery.
- 03 Although ETP has excellent corrosion resistance, it tends to rust in a humid atmosphere. Use as soon as possible after unpacking.
- 04 Tin is dissolved by a strongly alkaline solution. When using ETP for making cans for alkaline contents, paint the internal surface.
- 05 As contents that contain sulfur cause blackening of the ETP surface, paint the internal surface.

Information Required with Orders and Inquiries

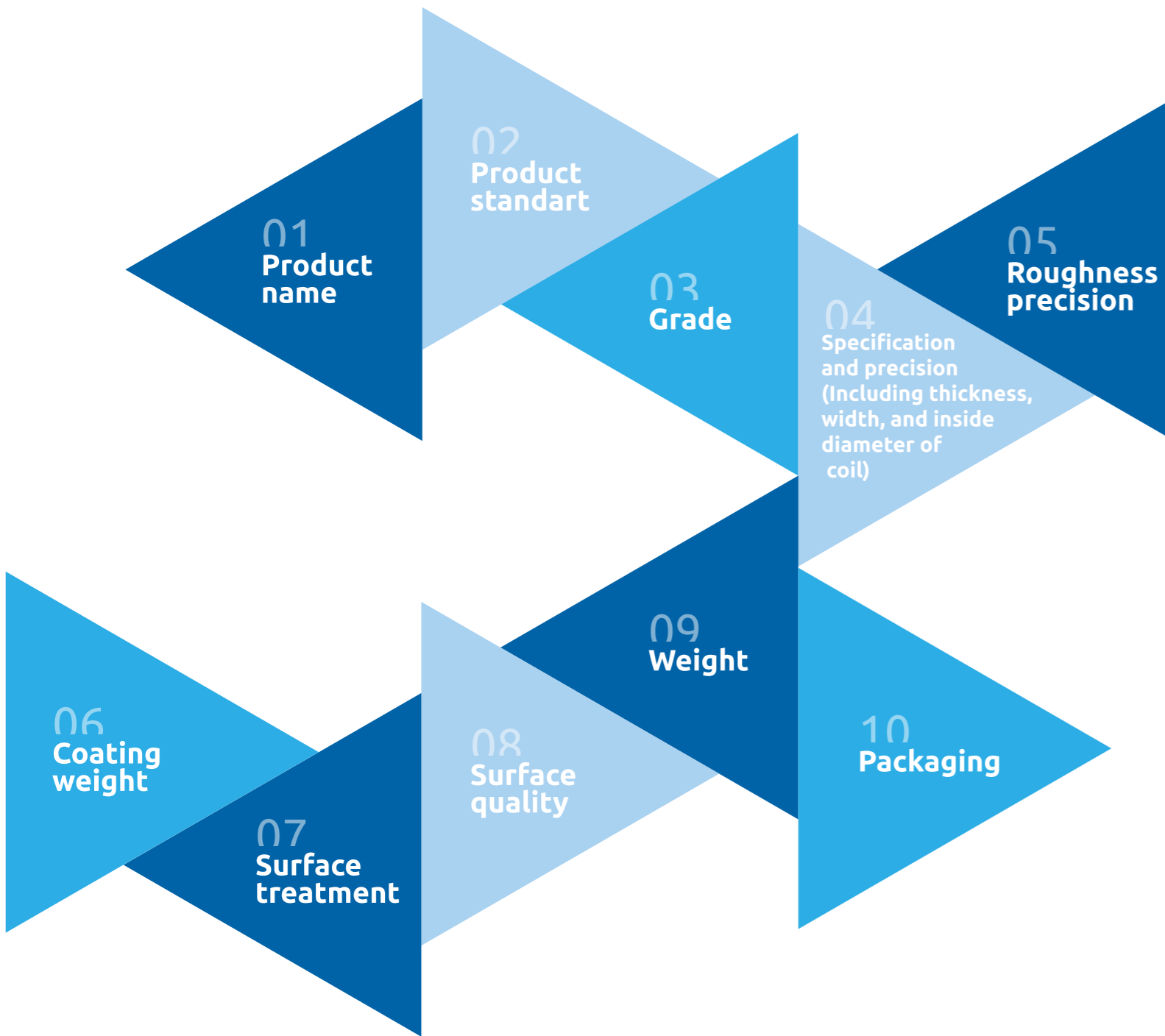

TIN FREE STEEL

Tin mill products include electrolytic tinplate, electrolytic chromium coated steel (also referred to as tin free steel or TFS), and black plate, the uncoated steel. Tinplate is a thin steel sheet coated by tin, while TFS is an electrolytic chrome plated steel consisting of a thin layer of chromium and a layer of chromium oxide deposited on the steel base. Both of them have a beautiful, metallic luster as well as excellent properties in corrosion resistance and paintability.

List of Tin Mill Products

Tin Mill Products

TFS	SR
	DR

Note : Tinplate Includes K-Tinplate, DI-Tinplate, Low-Tin Plate, L-Cr Tinplate.

TFS Products

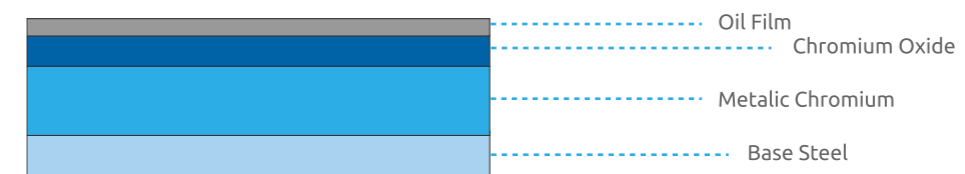

Features

Features of TFS Products

Excellent paint adhesion	TFS has excellent paint adhesion properties that far surpass those of ETP, allowing its use for making DRD cans and adhesive bonded cans.
Excellent heat resistance	High-temperature baking causes neither discoloration nor deterioration in material properties.
Excellent resistance to Sulphur Blackening	The metallic chromium in TFS has excellent sulphide resistance property when canning protein-rich foodstuff such as fish. TFS compensates for the expensive sulphur resistant lacquer.
Excellent filiform rust resistance	TFS has an excellent under film corrosion resistance.
Excellent alkali resistance	The coating in TFS is not amphoteric. Alkaline products such as detergents and dispersion colours can be packed in TFS with advantage.

Different Features between TFS and ETP

Appearance	Even when the same surface finish as ETP is applied to the substrate steel sheet, it provides the unique surface luster characteristic of metallic chromium.
Corrosion resistance	As it has excellent corrosion resistance after painting, it is generally used with both surfaces painted. It can also be used with the internal surface unpainted, depending on the contents.
Solderability	TFS is not compatible with soldering.
Weldability	Although TFS can be welded when the metallic coating layers are removed, its weldability is inferior to ETP.
Coating weights	Unlike the multiplicity of coating weights with tin, only one standardized chromium-coated product is manufactured.

Features

Comparison of Properties

		Tinplate		TFS
		2.8	Over 5.6	
Bare Corrosion Resistance (sealed) ⁽¹⁾	Rust Resistance	○	⊙	○
	Acid Resistance	○	○	△
	Alkali Resistance	△	△	⊙
	Black Sulfide Stain Resistance	△	△	⊙
	Stress Cracking Resistance	⊙	⊙	○
Paintability		○	○	⊙
Corrosion Resistance after Painting ⁽²⁾		⊙	⊙	○
Filiform Corrosion Resistance		⊙	⊙	⊙
Paint Adhesion		○	○	⊙
Formability		⊙	⊙	○
Solderability		○	⊙	×
Weldability		○	○	△ ⁽³⁾
Heat Resistance ⁽⁴⁾		○	○	⊙

⊙ excellent ○ good △ fair × poor

Note:

(1) Bare corrosion resistance is evaluated under tightly sealed conditions.

(2) Corrosion resistance after painting is evaluated by crosshatching corrosion tests.

(3) The evaluation is for the case where welding is performed without grinding the surface to remove the metallic coating layer.

(4) High-temperature baking after painting and printing may cause changes in material properties.

Applications of Tinplate and TFS

Consumer Packaging and Industrial Packaging

TINPALTE	ETP is primarily used for packaging foodstuffs and beverages, but it is also used in containers for oils, grease, paints, polishes, chemicals and many other products. Aerosol containers and caps and closures are also made from ETP.
TFS	TFS are most frequently used for can tops, screw and lug caps, snap and press-on closures and shallow-drawn food cans.

Miscellaneous

in Electronics	Electrodes, Cable tape, Magnetic screen covers, etc.
in Engineering	Automotive oil filters, Automotive air filters, Gaskets, etc.
in Construction	Gas meter internal components, Heat exchangers, cookware, shelving, etc.



Application Examples

DI can

Two-piece steel can represents the highest development level of tinplate production. Nowadays, Our DI material is used for two-piece can to pack beer and carbonated beverage such as CocaCola and Pepsi-cola.



Three-Piece Can For Beverage

Representative clients: include Wanglaoji, Redbull, Robust, etc.



Food can (3-piece can & 2-piece can)

Our tin mill products are used for the package of all kinds of canned food such as Huangguan, Meilin and Gulong.



Metal closure and ends

Our tinplate and TFS are used for Budweiser, Harbin and Yanjing beer, etc. Our the major supplier of Ziquan Group, Huapeng closures, Yiwu Easy Open End Industry Group, etc.



Spray can

Clients are Hangzhou Meite, Shenzhen Huate, zhongshan Kaida, etc.



High-grade industrial package

Tinplate and TFS are used for the package of Nippon, International Paint, Sigma.



High-grade gift package

Irregular cans are made from Our tinplate and TFS for high-grade gift package.



Manufacturing Process

Process Diagram

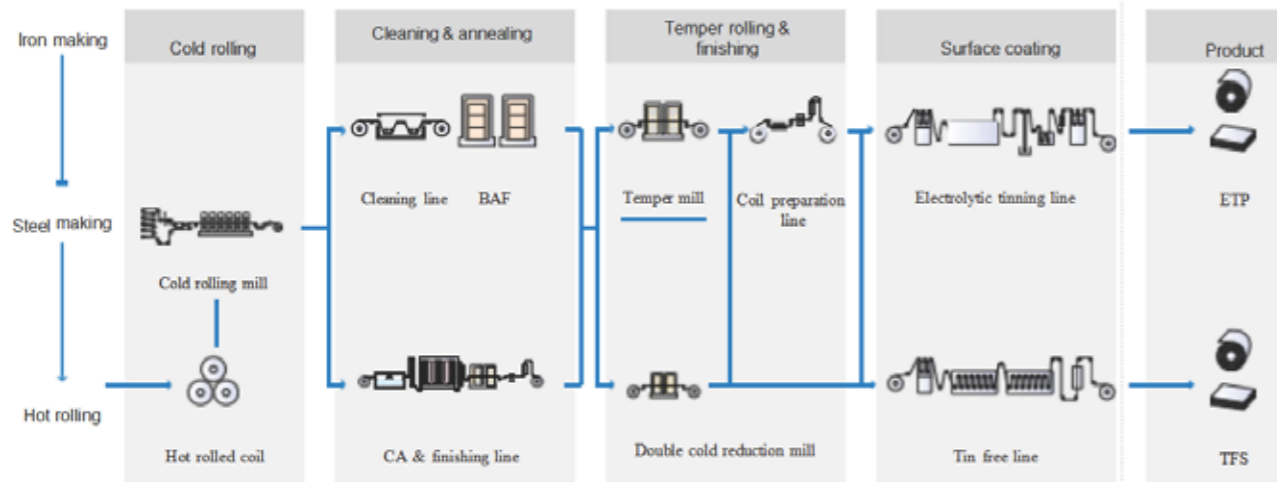

Note:
Tinplate and TFS products are manufactured under strict quality control all through the manufacturing process to provide the excellent corrosion resistance and uniform material properties required of can-making materials.



Major Control Items in the Manufacturing Process

Steelmaking	Steelmaking: Chemical composition, minimization of inclusions.
Hot Rolling	Finishing temperature, coiling temperature, gage profile.
Cold Rolling	Gage, flatness.
Annealing	Heating temperature, soaking temperature, cooling temperature, atmospheric gas composition.
Temper Rolling	Shape, surface roughness.
Electrolytic Plating	Coating weight, chemical treatment, oiling amount.

ETP and TFS's Parameters Inspected

A	Mechanical Properties	Hardness (temper grade)
B	Dimensional Accuracy	Thickness Width Cut-length
C	Shape Parameters	Bowness Camber Askewness Edge waviness
D	Lubrication	Oil film
E	Corrosion Resistant Property	Tin coating (for Tinplate) Metallic chromium and chromium in Cr-oxide (for TFS) Passivation film weight Alloy-tin Couple (for required) Iron solution value (for required) Tin grain size (for required) Corrosion resistance SO2 test (for required) Porosity Test (for required) Pickling lag value (for required)

Available Specifications and Sizes

Steel Types

Steel grade	Characteristics	Products
MR	Our low in residual elements that has excellent corrosion resistance, widely used in general applications.	ETP, TFS
L	Base steel extremely low in residual elements such as Cu, Ni, Co, and Mo that has excellent corrosion resistance to certain types of food products.	ETP, TFS
D	Aluminum-killed base steel used in applications involving deep drawing or other types of severe forming that tend to give rise to Lueder's lines.	ETP

Note:
With regard to steel types other than those listed above, please consult us.

Available Sizes

■ TFS

Black Plate	Normal Thickness	Normal Width	Normal Length(sheet)
Single Reduce	0.17 ~ 0.55mm	700 ~ 1050mm	500 ~ 1168mm
Double Reduce	0.12 ~ 0.36mm		

■ Temper Grade

Black Plate	Box Annealing
Single Reduce	T-1, T-2, T-2.5, T-3 T-1.5, T-2.5, T-3, T-3.5, T-4, T-5
Double Reduce	DR-7M, DR-8, DR-8M, DR-9, DR-9M, DR-10

Note:
(1) There are two types of annealing: batch annealing (BA) and continuous annealing (CA). When continuous annealing is designated, the symbol of "CA" is added after the temper grade symbol such as "T-4CA".
(2) The DR materials can also be manufactured by box annealing, Normal Width limited from 700~1050mm. Please consult us.

Coating Weight

■ TFS

Metallic Chromium Layer (one side)		Chromium Oxide Layer (one side)	
Minimum Average Coating Weight	Maximum Average Coating Weigh	Minimum Average Coating Weight	Maximum Average Coating Weigh
50 mg/m ²	150 mg/m ²	5 mg/m ²	35 mg/m ²

Surface Finishes

■ TFS

Black Plate	Code	Surface Finish	Characteristics
Single Reduce	B	Bright surface	Glazed surface obtained by a thin layer of chromium and chromium oxide deposited on the smooth steel base with extremely fine stone figures by processing.
	R	Stone surface	Glazed surface obtained after a thin layer of chromium and chromium oxidedeposited on the smooth steel base featuring certain oriented stone figures.
	R2	Stone rough surface	Glazed surface obtained after a thin layer of chromium and chromium oxidedeposited on the smooth steel base featuring certain oriented stone figures, roughness higher than "R".
Double Reduce	M	Matte surface	Matt surface.
	R	Stone surface	Glazed surface obtained after a thin layer of chromium and chromium oxidedeposited on the smooth steel base featuring certain oriented stone figures.

Oiling

■ If no engagement, tinplate and TFS are electro statically oiled with DOS.

▶ Packaging and Marking

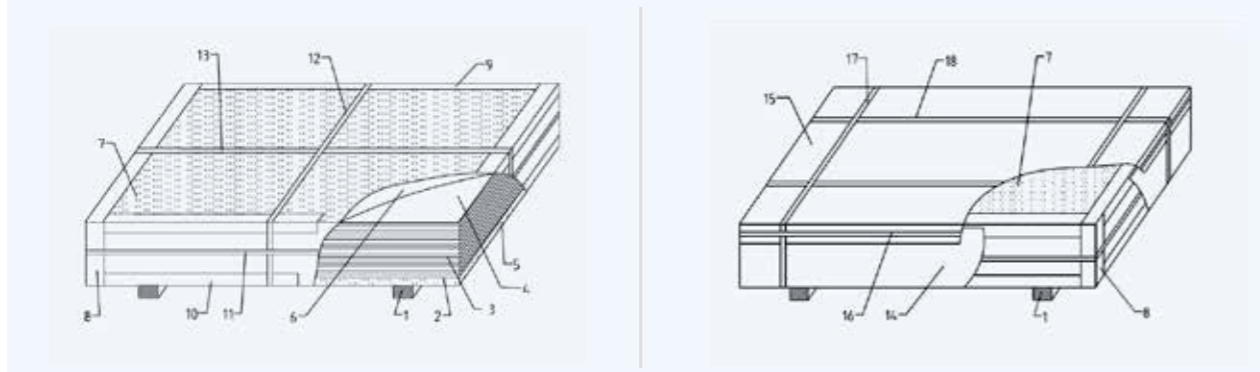

- 01 Wood bracket
- 02 Bottom cover
- 03 Steel sheet
- 04 Top cover
- 05 Bottom corrugated paper
- 06 Rust-proof paper
- 07 Top corrugated paper
- 08 Side corner guard
- 09 Top corner guard
- 10 Bottom corner guard
- 11 Circumferential banding strip (inner)
- 12 Horizontal banding strip (inner)
- 13 Vertical banding strip (inner)
- 14 Guard plate
- 15 Steel package box
- 16 Circumferential banding strip (outer)
- 17 Horizontal banding strip (outer)
- 18 Vertical banding strip (outer)

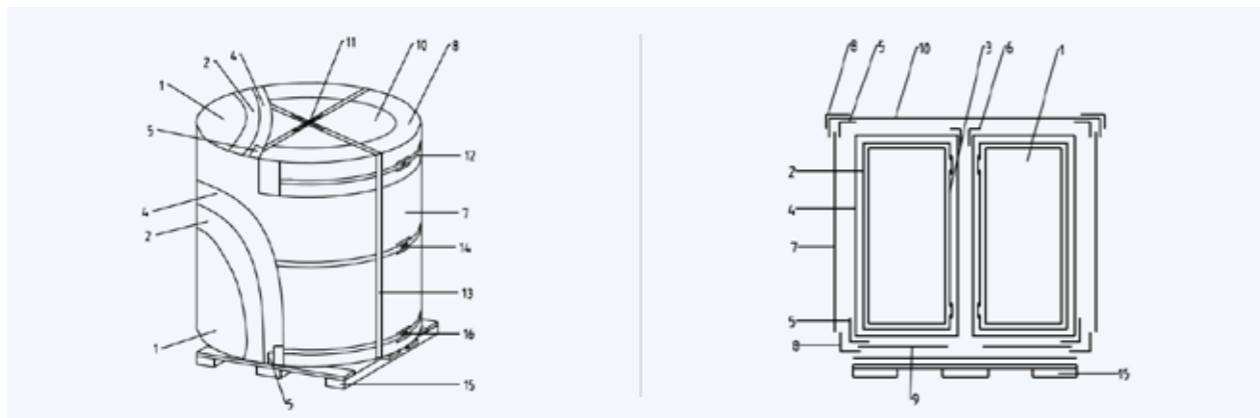

- 01 Steel coil
- 02 External peripheral rest-proof paper
- 03 Inner core rest-proof paper
- 04 Paper inner corner guard
- 05 Paper external corner guard
- 06 Iron round cover
- 07 Iron inner corner guard
- 08 Iron external corner guard
- 09 External peripheral wrapping plate
- 10 Inner peripheral guard plate
- 11 Circumferential banding strip
- 12 Radial banding strip
- 13 Shim for lock
- 14 Lock

Offers coils and sheets, coil packed in a vertical form or a horizontal.
 A label that indicates the manufacturing history is affixed to the outside of the packaging.
 In addition, a service card is contained inside.
 With regard to types of packing and markings, please consult us.

▶ Products Standard

TFS

- TFS orders are placed in accordance with Q/BQB 455-2009 standard which uses in a non-equivalent to JIS G 3315:2008, DIN EN 10202:2001, EN 10203 standards.

▶ List of Usual Specification

	Temper	Nominal Thickness (mm)	Nominal Width (mm)
SR-CA	T-1.5CA	0.22-0.25	700-840
		0.26-0.35	700-915
		0.36-0.49	790-960
	T-2.5CA	0.22	700-880
		0.23-0.26	700-1050
		0.27-0.45	700-1150
		0.46-0.55	900-1150
		0.18-0.19	700-840
	T-3CA	0.20-0.21	700-880
		0.22	700-940
		0.23-0.26	700-1050
		0.27-0.35	700-1150
		0.36-0.45	800-1150
		0.46-0.55	900-1150
		0.20-0.22	700-900
		0.23-0.32	700-1050
	T-3.5CA	0.33-0.50	800-1050
		0.18-0.22	700-1050
		0.23-0.26	700-1150
	T-4CA	0.27-0.36	700-1080
		0.18-0.22	700-1050
		0.23-0.26	700-1150
	T-5CA	0.27-0.29	700-960
		0.30-0.50	800-1000
0.26-0.5		800-1000	
T-2.5CA,T-3CA (IF)			

Note:
 Specific specifications are available on-site subject to the actual production.

	Temper	Nominal Thickness (mm)	Nominal Width (mm)	
SR-BA	T-2BA	0.22-0.50	700-960	
	T-2.5BA,T-3BA	0.19	700-860	
		0.20	700-900	
		0.21	700-920	
		0.22-0.23	700-940	
		0.24-0.50	700-960	
DR-CA	DR520 DR7M	0.15	700-880	
		0.16	700-920	
		0.17	700-940	
		0.18-0.28	700-970	
		0.29-0.40	800-970	
	DR550 DR8	0.14	700-880	
		0.15-0.16	700-920	
		0.17-0.26	700-970	
		0.27-0.38	800-970	
	DR580 DR8M	0.14	700-920	
		0.15	700-950	
		0.16-0.25	700-970	
		0.26-0.36	800-1000	
	DR620 DR9	0.14	700-940	
		0.15-0.23	700-970	
		0.24-0.34	800-1000	
	DR-BA	DR520 DR7M	0.15	700-880
			0.16-0.17	700-900
0.18-0.40			700-960	
DR550 DR8		0.14	700-820	
		0.15	700-900	
		0.16	700-920	
		0.17-0.37	700-960	

Usage Precautions

Usage Precautions for TFS

- 01 TFS is not compatible with soldering and DI forming. However, once painted, it can be used in almost all applications where TIN PLATE is used.
- 02 The metallic coating layer of TFS has a high electrical resistance. When welding it, the metallic coating layers in the welded areas should be removed in advance.
- 03 TFS tends to rust in a humid atmosphere. Use as soon as possible after unpacking.
- 04 The external surfaces of cans should be painted to prevent corrosion. The internal surfaces should also be painted to prevent corrosion except when the content is motor oil or cooking oil.
- 05 TFS does not provide sacrificial protection like TIN PLATE. Due precautions should be taken not to cause scratches on the surface of TFS after it is formed into cans and painted.

Information Required with Orders and Inquiries

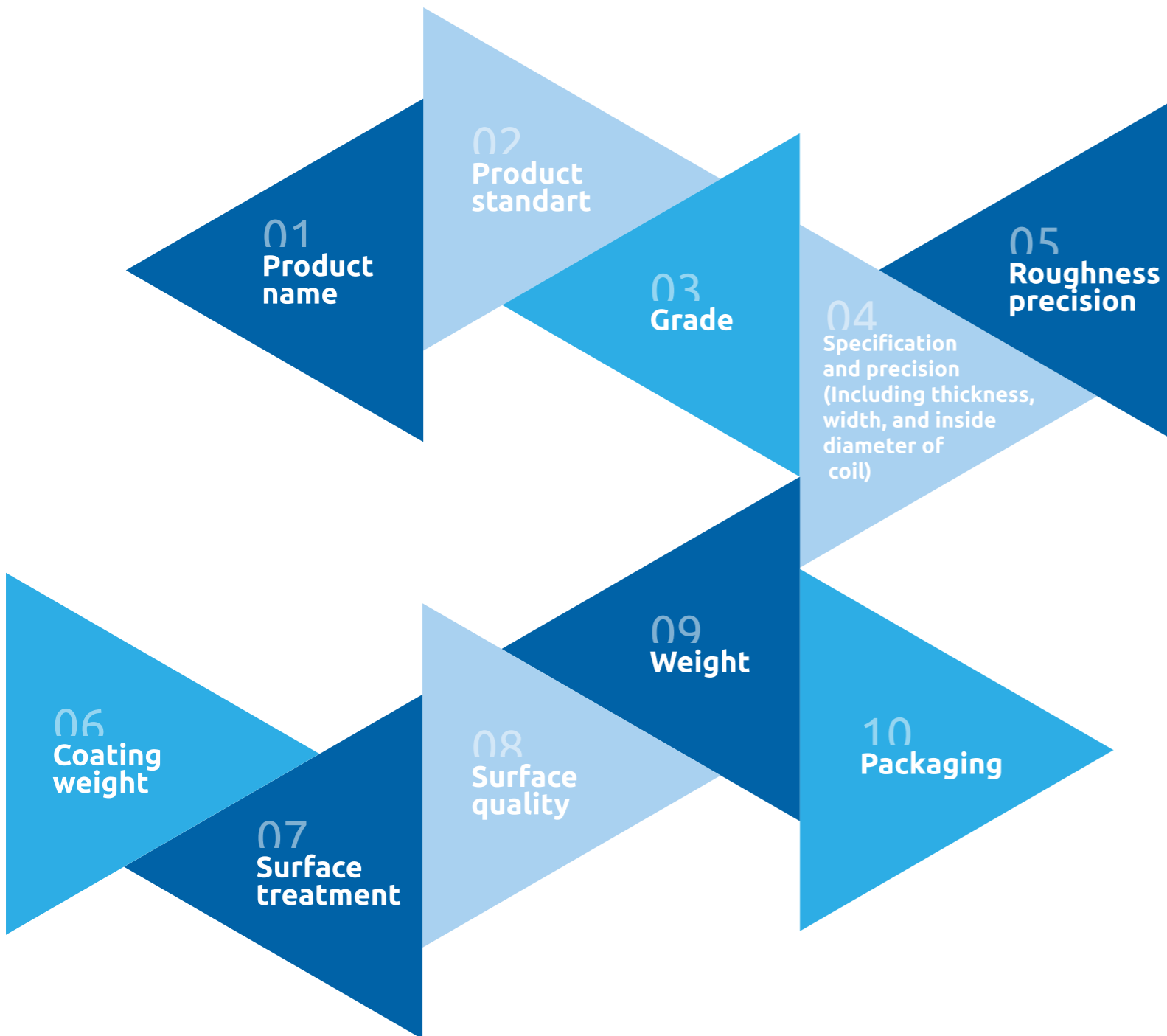

FILM – LAMINATED STEEL

Laminated Steel is environment-friendly packaging material which is made of the multi-polymer film and the steel base, the steel trip such as TFS(Tin Free Steel) or ECCS(Electrolytic Chrome Coated Steel), electrolytic tinplate and cold rolling steel is combined with resin such as polyethyleneterephthalate (PET), polypropylene(PP) by heating and melting. Laminated Steel can preserve food effectively with excellent merits in corrosion resistance, forming, lacquering, and so forth.

List of Products

TFS-Based Film-Laminated Steel	Single Reduced TFS-Base Film-Laminated Steel
	Double Reduced TFS-Base Film-Laminated Steel
Tinplate-Based Film-Laminated Steel	Single Reduced Electrolytic Tinplate-Base Film-Laminated Steel
	Double Reduced Electrolytic Tinplate-Base Film-Laminated Steel

Note:

Baosteel Film-Laminated Steel is classified into 4 sub groups as follows.

BFG stands for General Film-Laminated Steel

BFE stands for Film-Laminated Steel with High Elongation

BFA stands for Film-Laminated Steel with High Adhesion

BFX stands for Film-Laminated Steel with Special and High Requirement

Product / Film Structure

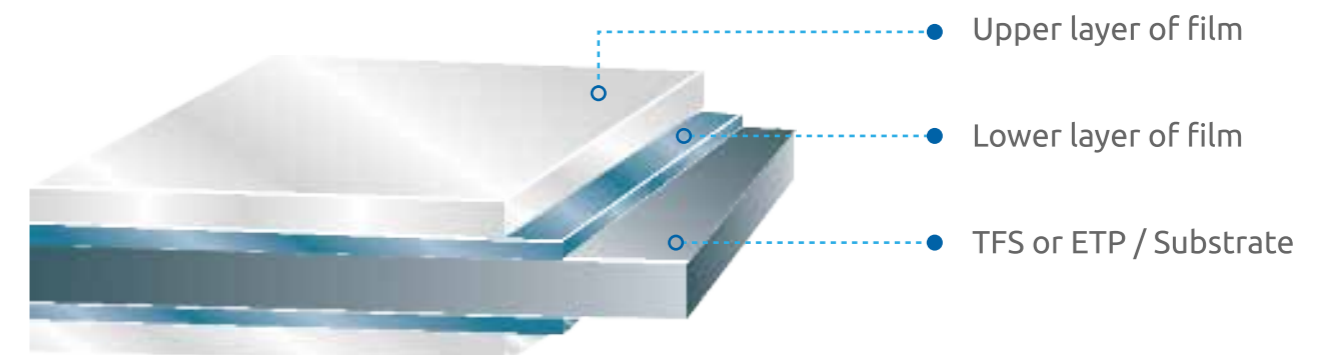

Features

01 Advantages Of Laminated Steel

- Free from toxic/Food Safety: Keeping food hygienic and safe because of the film constituting no hazardous substance and the process without the adhesive and solvent.
- Environment-friendly: No solvent and exhaust emission without coating and curing process, accordingly there is less pollution and energy consumption.

02 Product Performance

- Excellent Barrier: The immutable and stable film as an excellent barrier layer can separate the corrosive substance from steel base, thereby preserving food better during shelf life.
- Excellent Formability: The film with higher strength and elongation and wear-resisting significantly improves on the complicated formability of laminated steel.
- Excellent Printability: The film with excellent adhesion to ink makes printing convenient, and enhances color fastness and vividness and brilliant appearance.

03 Technology Characteristics

- Complete manufacturing Process, steelmaking, hot rolling, cold rolling and TFS or ETP lines, the base steel for laminating covers TFS, ETP and CR plate.
- Autonomous integration technology, film fabrication, laminating process, equipment technology, and application research, contributing to the excellent properties of products.
- Online Quality Control, online pinhole detector monitoring film quality, and with online laminating temperature controller exerting precise adjustment, so that the excellent properties and quality steadiness of products is guaranteed.

Applications

Our laminated steel can be used as packaging material not only for food and beverage but also for chemicals such as oil, paint, polymer, spray agent. It is liable to be shaped into can bodies and accessories including DRD (Draw & redraw) can, DWI (Draw-Wall-Iron) can, twist off cap, EOE(Easy-Open-End), top ends, other 2-piece can bodies, and so forth.

DRD Can



Top or bottom End



Easy Open End



Manufacturing Process

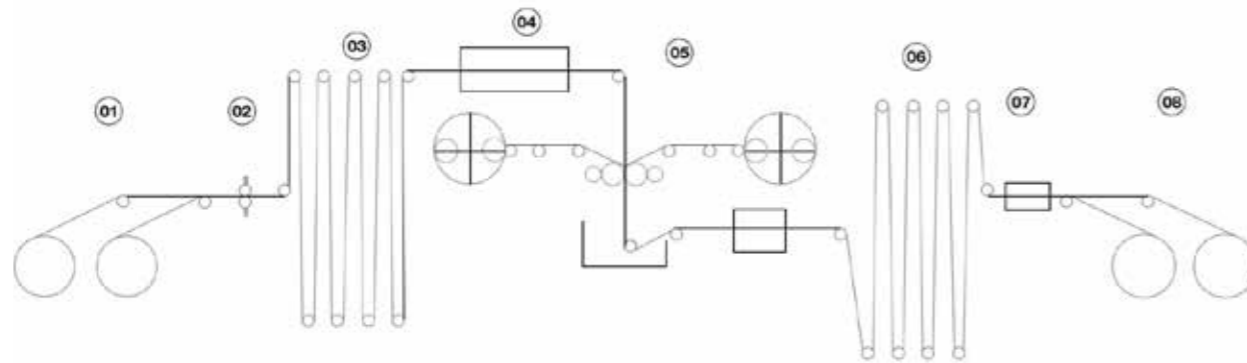

- 01 Uncoiler
- 02 Welder
- 03 Entry
- 04 Looper Heating Unit
- 05 Laminating
- 06 Section Exit Looper
- 07 Wax
- 08 Coating Coiler

Available Specification and Size

01 Available Size

- TFS-Based Film-Laminated Steel

Steel Base	Nominal Gauge	Nominal Width	Nominal Length (For Sheets)
SR	0.17~0.38mm	700~1200mm	500~1168mm
DR	0.14~0.36mm	700~970mm	

- Tinplate-Base Film-Laminated Steel

Steel Base	Nominal Gauge	Nominal Width	Nominal Length (For Sheets)
SR	0.17~0.38mm	700~1200mm	500~1168mm
DR	0.14~0.36mm	700~970mm	

02 Temper Grade

Steel Base	Continuous Annealing
SR	T-1.5, T-2.5, T-3, T-3.5, T-4, T-5
DR	DR-7M, DR-8, DR-8M, DR-9

03 Film Thickness and Color

Film	Nominal Thickness of Single Side
Clear	12~30μ
White	
Golden	

04 Lubricating

- There is food grade wax on surface of product unless otherwise agreed.

Instruction and Precaution

- 01 Due to softness of film, please take action to prevent it from scratch during delivery.
- 02 Due to the performance variation, please put it into production as soon as receiving the goods.
- 03 Due to the moisture damaging to the laminated steel, please use up the unpacked material as soon as possible.

▶ Packaging And Marking

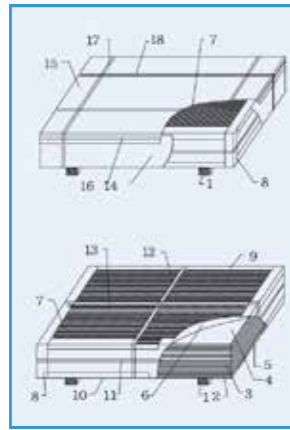

- | | | |
|-----------------------------------|---|--|
| 01 wood bracket | 07 corrugated paper side | 13 13 vertical banding strip (inner) |
| 02 bottom cover | 08 corner guard top corner | 14 guard plate |
| 03 steel sheet top | 09 guard | 15 steel package box |
| 04 cover | 10 bottom corner guard circumferential | 16 circumferential banding strip(outer) |
| 05 bottom corrugated paper | 11 banding strip(inner) | 17 horizontal banding strip(outer) vertical |
| 06 rust-proof paper top | 12 horizontal banding strip (inner) | 18 banding strip(outer) |

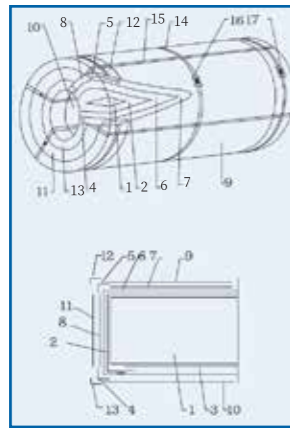

- | | | |
|-----------------------------------|---|--|
| 01 wood bracket | 07 corrugated paper side | 13 13 vertical banding strip (inner) |
| 02 bottom cover | 08 corner guard top corner | 14 guard plate |
| 03 steel sheet top | 09 guard | 15 steel package box |
| 04 cover | 10 bottom corner guard circumferential | 16 circumferential banding strip(outer) |
| 05 bottom corrugated paper | 11 banding strip(inner) | 17 horizontal banding strip(outer) vertical |
| 06 rust-proof paper top | 12 horizontal banding strip (inner) | 18 banding strip(outer) |

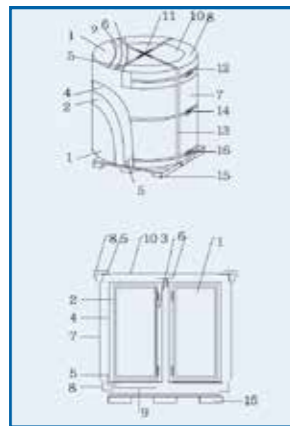

- | | | |
|-----------------------------------|---|--|
| 01 wood bracket | 07 corrugated paper side | 13 13 vertical banding strip (inner) |
| 02 bottom cover | 08 corner guard top corner | 14 guard plate |
| 03 steel sheet top | 09 guard | 15 steel package box |
| 04 cover | 10 bottom corner guard circumferential | 16 circumferential banding strip(outer) |
| 05 bottom corrugated paper | 11 banding strip(inner) | 17 horizontal banding strip(outer) vertical |
| 06 rust-proof paper top | 12 horizontal banding strip (inner) | 18 banding strip(outer) |

Feasible In Coils And Sheets , Coil Packed Eye To The Sky Or Eye To The Wall.

A Label That Indicates The Manufacturing History Is Affixed To The Outside Of The Packaging. In Addition, A Service Card Is Contained Inside.

With Regard To Types Of Packing And Markings, Please Consult Us.

▶ Product Standard or Protocol

- Orders are in accordance with the technical agreement numbered as BKJ16-915-601.

▶ Requested Information of order or Inquiry

- Product name
- Product standard or Technical Protocol
- Temper grade
- Specification and tolerance of steel base(Including thickness, width, inside diameter of coil, length of sheets, etc)
- Thickness and color of film
- Lubricant weight
- Weight
- Packaging
- End Use
- Type of content